



# INSTALLATION INSTRUCTIONS

Accessory

**TANK BAG**  
P/N 08L71-MKJ-D00

Application

**CB650RA**  
**CBR650RA**

Publication No.

**MII**

Issue Date

**September 2018**

**Honda Dealer: Please give a copy of these instructions to your customer.**

## PARTS LIST

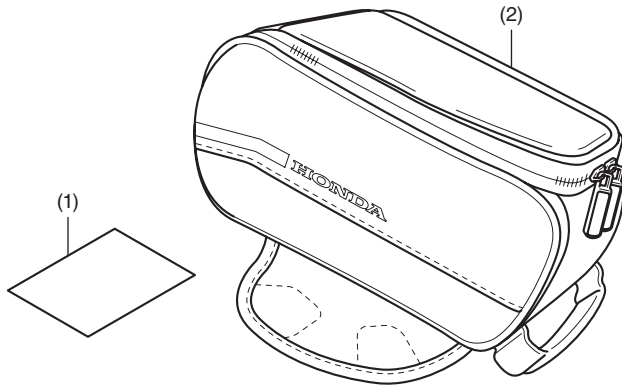

No.	Description	Qty
(1)	URL paper	1
(2)	Tank bag	1

### TANK BAG ATTACHMENT

Sold separately

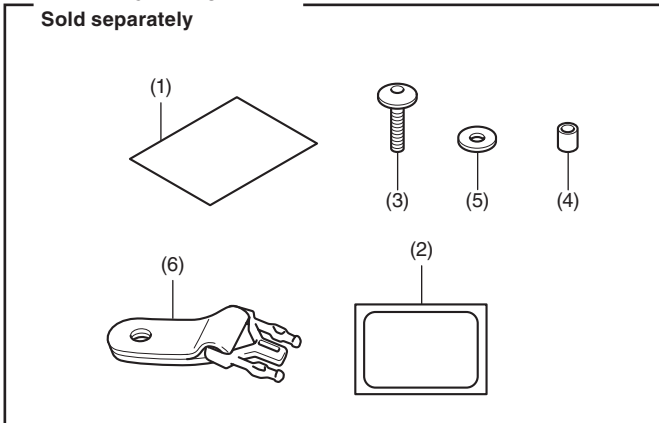

No.	Description	Qty
(1)	URL paper	1
(2)	Protection film	2
(3)	6 mm screw	2
(4)	Collar	2
(5)	Washer	2
(6)	Tank bag strap	2

## TOOLS AND SUPPLIES REQUIRED

- Hex wrench (5 mm)
- Scale
- Scissors
- Isopropyl alcohol
- Shop towel
- Torque wrench

## TORQUE CHART

Tighten all screws, bolts, and nuts to their specified torque values. Refer to the Service Manual for the torque values of the removed parts.

Item	N-m	kgf-m	lbf-ft
6 mm screw	9	0.9	6.6

## MAXIMUM LOADING CAPACITY

- The weight of the cargo must not exceed the following maximum loading capacity:

Maximum Loading Capacity	
Tank bag	1.0 kg (2.2 lb)

## INSTALLATION

### ▲ CAUTION

- To prevent burns, allow the engine, exhaust system, radiator, etc., to cool before installing the accessory.

### NOTE:

- Heat the bonding surfaces with a hair dryer if the ambient air temperature is below 70°F (21°C).
- The adhesive reaches full strength in 72 hours. Wait at least 24 hours before riding your motorcycle.
- Before installation, remove all dust, sand, etc. from fuel tank and tank bag, as otherwise the fuel tank may be damaged.
- Although the illustration is of CB650RA, use the same procedures for other models.

- Remove the screws as shown.

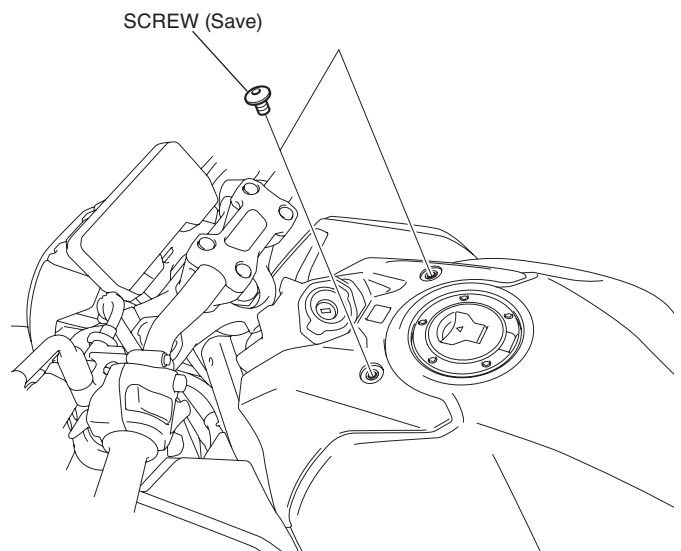

2. Cut the protection film to the dimensions shown.

<For left side>

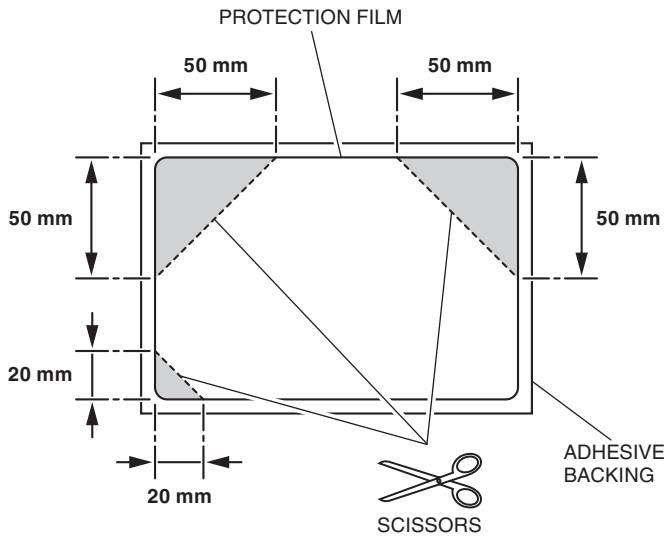

<For right side>

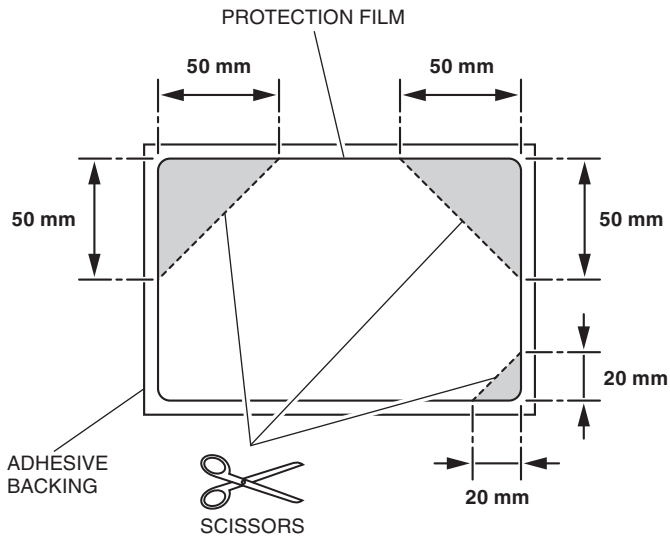

3. Clean the surface of the area shown using an isopropyl alcohol.

<Left side>

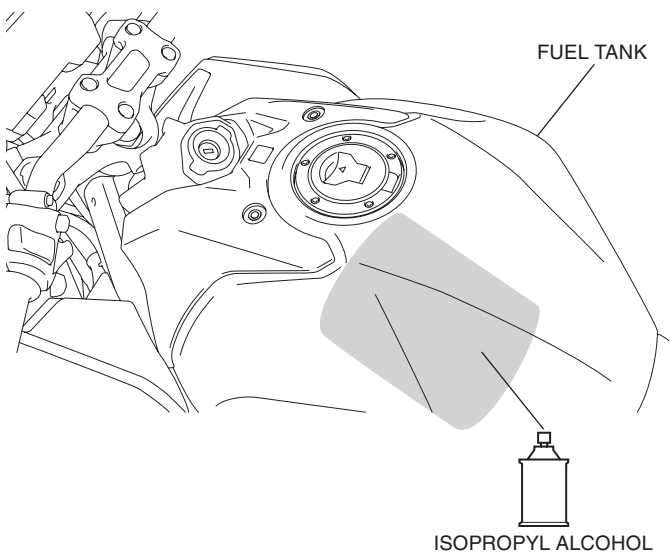

4. Attach the protection film to the fuel tank as shown.

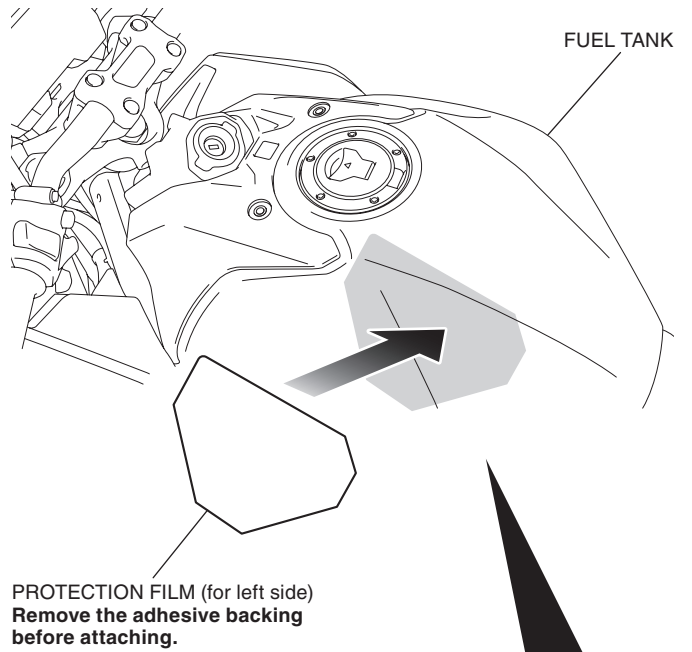

Remove the adhesive backing before attaching.

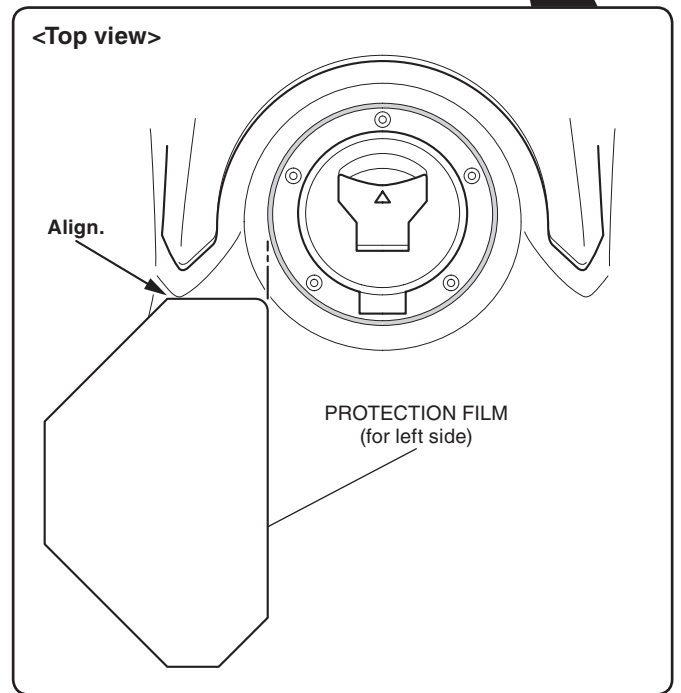

5. Attach the right side in the same manner as the left side.

6. Install the tank bag straps as shown.

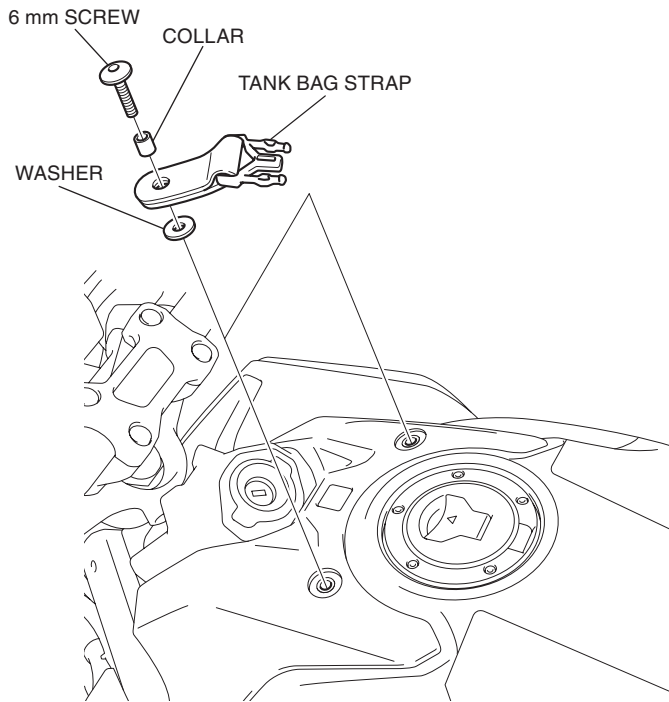

7. Install the tank bag on the fuel tank as shown.

